

The Germanic Languages and the SOV/SVO difference

III. SOV/SVO and Predicative Adjective Agreement

Sten Vikner

Department of English, Institute of Language, Literature & Culture,
University of Aarhus, DK-8000 Århus C, Denmark

sten.vikner@hum.au.dk - *http://www.hum.au.dk/engelsk/engsv*

Contents

Abstract,

1. Introduction, 2
2. Scandinavian, 3
3. West Germanic, 4

4. Explaining the differences, 9
5. The subject originates inside the predicative AdjP, 10
6. Predicative adjective agreement is spec-head agreement inside AdjP, 11
7. Spec-head agreement is a property of head-initial phrases, 12

8. Predictions, 13
 - 8.1 Historical predictions, 14
 - 8.2 Adjective agreement in causatives, 15
 - 8.3 Participle agreement, 16
9. Conclusion, 18

References, 19

Abstract

Among the Germanic and Romance languages, the languages that lack predicative adjective agreement without lacking attributive adjective agreement are all SOV languages (including Yiddish). I will link this to the OV/VO-difference, based on the Optimality Theory analysis of this difference given in Vikner (2001b).

This hand-out is based on Vikner (2001a).

1. Introduction

German would seem to have much more morphology than e.g. French or Danish. However, there is one area where German agreement morphology could not possibly be simpler, and where German is much easier for non-native speakers than e.g. French or even Danish: predicative adjectives. Both gender and number distinctions, (1a-b), disappear when adjectives are used predicatively, (1c-f):

- (1) Ge. a. ein grüner Bus / zwei grüne Busse
a.M.NOM green.M.SG.NOM bus two green.PL.NOM buses
b. ein grünes Haus / zwei grüne Häuser
a.N.NOM green.N.SG.NOM house two green.PL.NOM houses
- c. Ein Bus ist grün_, (die anderen sind gelb)
One.M.NOM bus is green_, (the others are yellow)
d. Zwei Busse sind grün_, (die anderen sind gelb)
Two buses are green_, (the others are yellow)
- e. Ein Haus ist grün_, (die anderen sind gelb)
One.N.NOM house is green_, (the others are yellow)
f. Zwei Häuser sind grün_, (die anderen sind gelb)
Two houses are green_, (the others are yellow)

Compare this to the situation in French (and all other Romance languages), where the inflectional differences found in the attributive construction are also found in the predicative construction:

- (2) Fr. a. un autobus vert_ / deux autobus verts
a.M bus green.M.SG two buses green.M.PL
b. une maison verte / deux maisons vertes
a.F house green.F.SG two houses green.F.PL
- c. Un autobus est vert_ , (tous les autres sont jaunes)
One.M bus is green.M.SG, (all the others are yellow)
d. Deux autobus sont verts, (tous les autres sont jaunes)
Two buses are green.M.PL, (all the others are yellow)
- e. Une maison est verte, (toutes les autres sont jaunes)
One.F house is green.F.SG, (all the others are yellow)
f. Deux maisons sont vertes, (toutes les autres sont jaunes)
Two houses are green.F.PL, (all the others are yellow)

In the following sections, the situation in the other Germanic languages will be examined.

2. Scandinavian

Danish (and also Norwegian and Swedish) are like French, exactly the same inflectional differences are found in the attributive construction and in the predicative construction :

- (3) Da. a. en grøn_ bus / to grønne busser
a.M/F green.M/F.SG bus two green.PL buses
 b. et grønt hus / to grønne huse
a.N green.N.SG house two green.PL houses
 c. En bus er grøn_, (de andre er gule)
One.M/F bus is green.M/F.SG, (the others are yellow)
 d. To busser er grønne, (de andre er gule)
Two buses are green.PL, (the others are yellow)
 e. Et hus er grønt_, (de andre er gule)
One.N house is green.N.SG, (the others are yellow)
 f. To huse er grønne, (de andre er gule)
Two houses are green.PL (the others are yellow)

(These inflectional endings are only found in indefinite DPs. In definite DPs, attributive adjectives display no number or gender differences, cf. the form *grønne* in (33) below).

The situation is no simpler in those Scandinavian languages which have retained a rich inflectional system, Faroese and Icelandic:

- (4) Fa. a. ein grønur bussur / tveir grøni_r bussar
a.M green.M.NOM.SG bus two.M green.M.NOM.PL buses
 b. eitt grønt_ hús / tvey grøn_ hús
a.N green.N.NOM.SG house two.N green.N.NOM.PL houses
 c. Ein bussur er grønur
One.M bus is green.M.NOM.SG
 d. Tveir bussar eru grøni_r
Two.M buses are green.M.NOM.PL
 e. Eitt hús er grønt_
One.N house is green.N.NOM.SG
 f. Tvey hús eru grøn_
Two.N houses are green.N.NOM.PL
- (5) Ic. a. grønn_ strætisvagn / tveir græni_r strætisvagnar
(a) green.M.NOM.SG bus two.M green.M.NOM.PL buses
 b. grønt_ hús / tvö græn_ hús
(a) green.N.NOM.SG house two.N green.N.NOM.PL houses
 c. Einn strætisvagn er grønn_
One.M bus is green.M.NOM.SG
 d. Tveir strætisvagnar eru græni_r
Two.M buses are green.M.NOM.PL
 e. Eitt hús er grønt_
One.N house is green.N.NOM.SG
 f. Tvö hús eru græn_
Two.N houses are green.N.NOM.PL

Agreement is thus found in predicative adjective constructions in all the Romance and all the Scandinavian languages, irrespective of whether these have a rich inflectional system (like Icelandic, Faroese, or French) or a relatively poor one (like Danish, Norwegian, and Swedish).

3. West Germanic

Is German unique in not having agreement in predicative adjective constructions? No.

Two situations have to be kept apart: Languages which trivially lack predicative adjective inflection, because they do not have any adjectival inflection at all, and languages which only lack adjectival inflection in predicative adjective constructions, but have adjectival inflection in attributive constructions.

Two Germanic languages lack adjectival inflection completely, English and Afrikaans:

- (6) En. a. a green_ bus / two green_ buses
b. a green_ house / two green_ houses
- c. One bus is green_
d. Two buses are green_
- e. One house is green_
f. Two houses are green_
- (7) Af. a. 'n groen_ bus / twee groen_ busse
a green bus two green buses
b. 'n groen_ huis / twee groen_ huizen
a green house two green houses
- c. Een bus is groen_
One bus is green
d. Twee busse is groen_
Two buses are green
- e. Een huis is groen_
One house is green
f. Twee huizen is groen_
Two houses are green

The other West Germanic languages all lack adjectival inflection ONLY in predicative adjective constructions, and NOT in attributive adjective constructions. We have already seen the German data in (1) above, and the following examples show that the situation is completely parallel in Dutch, West Flemish, Frisian, Swabian, three types of Swiss German (from Sankt Gallen, Zürich, Bern), and finally Yiddish:

- (8) Du. a. een groene bus / twee groene bussen
a green.M/F bus two green.PL buses
b. een groen_ huis / twee groene huizen
a green.N.SG house two green.PL houses
- c. Een bus is groen_
One bus is green
d. Twee bussen zijn groen_
Two buses are green
- e. Een huis is groen_
One house is green
f. Twee huizen zijn groen_
Two houses are green

- (9) WF. a. *nen groenen bus / twee groene bussen*
a.M/F green.M/F bus two green.PL buses
- b. *een groen_ us / twee groene uzen*
a.N green.N.SG house two green.PL houses
- c. *T' is eenen bus groen_*
There is one bus green
- d. *T zyn twee bussen groen_*
There are two buses green
- e. *T' is een us groen_*
There is one house green
- f. *T zyn twee uzen groen_*
There are two houses green
- (10) Fs. a. *in griene bus / twa griene bussen*
a green.M/F bus two green.PL buses
- b. *in grien_ hûs / twa griene huzen*
a green.N.SG house two green.PL houses
- c. *Ien bus is grien_*
One bus is green
- d. *Twa bussen binne grien_*
Two buses are green
- e. *Ien hûs is grien_*
One house is green
- f. *Twa huzen binne grien_*
Two houses are green
- (11) St. a. *an grin_ Bus / zwoi grine Bus*
a.M.NOM green.M.SG.NOM bus two green.PL.NOM buses
- b. *a grins Haus / zwoi grine Heisr*
a.N.NOM green.N.SG.NOM house two green.PL.NOM houses
- c. *Oin Bus isch grin_*
One.M.NOM bus is green
- d. *Zwoi Bus sen grin_*
Two buses are green
- e. *Oi Haus isch grin_*
One.N.NOM house is green
- f. *Zwoi Heisr sen grin_*
Two houses are green
- (12) SG. a. *än grüene Bus / zwei grüeni Bûs*
a.M.NOM green.M.SG.NOM bus two green.PL.NOM buses
- b. *äs grües Huus / zwei grüeni Hüser*
a.N.NOM green.N.SG.NOM house two green.PL.NOM houses
- c. *Ain Bus isch grüe_*
One.M.NOM bus is green
- d. *Zwei Bûs sind grüe_*
Two buses are green
- e. *Ais Huus isch grüe_*
One.N.NOM house is green
- f. *Zwei Hüser sind grüe_*
Two houses are green

- (13) Zü. a. en grünee Bus / zwäi grünei Büs
a.M.NOM green.M.SG.NOM bus two green.PL.NOM buses
 b. es grünes Huus / zwäi grünei Hüscher
a.N.NOM green.N.SG.NOM house two green.PL.NOM houses
- c. Äin Bus isch grüne_
One.M.NOM bus is green
 d. Zwäi Büs sind grüne_
Two buses are green
- e. Äis Huus isch grüne_
One.N.NOM house is green
 f. Zwäi Hüscher sind grüne_
Two houses are green
- (14) Be. a. ei grünee Böss / zwe grünei Bösse
a.M.NOM green.M.SG.NOM bus two.M.NOM green.PL.NOM buses
 b. eis grünes Huus / zwöi grünei Hüser
a.N.NOM green.N.SG.NOM house two.N.NOM green.PL.NOM houses
- c. Ei Böss isch grüne_
One.M.NOM bus is green
 d. Zwe Bösse si grüne_
Two.M.NOM buses are green
- e. Eis Huus isch grüne_
One.N.NOM house is green
 f. Zwöi Hüser si grüne_
Two.N.NOM houses are green
- (15) Yi. a. a grinere oytobus / tsvey grinee oytobusn
a green.M.SG.NOM bus two green.PL buses
 b. a grin_ hoyz / tsvey grinee hayzer
a green.N.SG house two green.PL houses
- c. Eyn oytobus iz grin_
One bus is green
 d. Tsvey oytobusn zaynen grin_
Two buses are green
- e. Eyn hoyz iz grin_
One house is green
 f. Tsvey hayzer zaynen grin_
Two houses are green

The possibilities given for Yiddish in (15) above do not give the complete picture. In plural, Yiddish predicative adjectives might seem also to be possible with agreement:

(16) Yi. Tsvey oytobusn zaynen grine
Two buses are green.PL

However, I shall follow e.g. Weinreich (1971:308), Katz (1987:87), and Lockwood (1995:112) in taking the agreeing form in (16) to be a nominalisation. Lockwood (1995:112):

"Exceptionally frequently, [Yiddish] adjectives (including participles) in predicative position are nominalisations". In other words, (16) would correspond to English "two buses are green ones" (see Olsen 1988:345 and Delsing 1993:86 on nominalised attributive adjectives). This analysis is based on the fact that the possibilities for inflected predicative adjectives in the singular are:

(17) Yi. a. *Eyn oytobus iz griner
b. Eyn oytobus iz a griner
One bus is (a) green.M.SG.NOM

which makes it clear that the Yiddish for "one bus is green" must use an uninflected adjective, cf. (15c), and that the only way to have an inflected adjective in a predicative construction is to use the expression corresponding to "one bus is a green one", namely (17b).

Also a further remark on Afrikaans is in order, even though there is no reason to question the picture given in (7) above that Afrikaans has no predicative adjective agreement. It is the situation concerning attributive adjectives in Afrikaans which is more complex than (7) might indicate.

Like predicative adjectives, attributive adjectives show no agreement in Afrikaans. Some polysyllabic attributive adjectives (Lass 1990:88-95, Donaldson 1993:163, Ponelis 1993:366) have an affix (-e), which is diachronically derived from an agreement ending (Lass 1990:88-90, Ponelis 1993:364), but shows no distinctions of number, gender, or case:

(18) Af. a. 'n reusagtige bus / twee reusagtige busse
a huge.ATT bus two huge.ATT buses
b. 'n reusagtige huis / twee reusagtige huise
a huge.ATT house two huge.ATT houses
c. Een bus is reusagtig_
One bus is huge
d. Twee busse is reusagtig_
Two buses are huge
e. Een huis is reusagtig_
One house is huge
f. Twee huise is reusagtig_
Two houses are huge

The analysis to be suggested below will only be able to account for this in so far as it will account for why earlier stages of Afrikaans (like modern Dutch, modern German, ...) had agreement on attributive adjectives and not on predicative ones. In other words, whereas it will not explain why some attributive adjectives in Afrikaans have kept a residue of agreement morphology (i.e. they might as well all have lost the endings completely as in English), the analysis predicts that if such a residue should be found anywhere in the Afrikaans adjective system, it would be in the attributive forms, not in the predicative ones.

Summing up, the overall picture is as follows: Of all the Romance and Germanic languages, only the West Germanic ones lack predicative adjective agreement. English and Afrikaans lack both attributive and predicative adjective agreement, the other West Germanic languages lack only predicative adjective agreement.

(19)

			Attributive adjective agreement
			Predicative adjective agreement
a.	+	+	Romance, Scandinavian
b.	+	-	Dutch, German, Frisian, Yiddish (& their dialects)
c.	-	+	----- (no languages)
d.	-	-	Afrikaans, English

4. Explaining the differences

The observations made in the preceding sections are not completely new. They have also been made, at least partially, in e.g. Haugen (1982:173), Abraham (1995:245), and Kester (1996:89, 92), although these works merely note the difference and do not try to relate them to other differences between the languages in question.

The goal of an account of the adjective agreement facts should be to explain why the West Germanic languages lack predicative adjective agreement, why the Scandinavian and the Romance languages have it, and why it is not the other way around. This is only possible if the adjective agreement facts are related to other properties of the languages in question.

In the following, I would like to suggest an analysis which relates the facts discussed to other properties of the languages in question. So far we have seen that the two groups could be described as

- (20) 1. Predicative adjective agreement: Romance, Scandinavian
2. No predicative adjective agreement: West Germanic

but unless this is related to other differences, it remains as descriptive as the treatments cited above. I shall suggest that the crucial property is whether verb phrases and adjective phrases are head-initial or head-final, making a slightly different division between the languages:

- (21) 1. Head-initial VPs and AdjPs (VO): English, Romance, Scandinavian
2. Head-final VPs and AdjPs (VO): All West Germanic languages except English

It is not always possible simply to take the surface word order as an indication of head-finality (or the opposite). Cases where surface word order seem to conflict with the above classification include the assumption that Yiddish has a head-final VP. As in hand-outs II & IV and Vikner (2001b, 2003), I shall follow e.g. Hall (1979), Geilfuß (1991) and Haider & Rosengren (1998:78-81, 2003:253-255), against e.g. Santorini (1993), Diesing (1997), in assuming Yiddish to be an OV-language.

Now English belongs to group (21.1) where it before belonged to group (20.2). This regrouping of English has no empirical consequences, however, as it merely says that English **could** have predicative adjective agreement, not that it **has to** have it. To be more precise, given the predictions spelled out in (26) below, the prediction for a VO-language is that it either has agreement with both attributive and predicative adjectives (e.g. Danish) or with neither (English). The prediction for an OV-language is that it either has agreement only with attributive adjectives (e.g. German) or with neither (Afrikaans).

5. The subject originates inside the predicative AdjP

According to Delsing (1993:84), "normally, linguists assume, implicitly or explicitly, that predicative adjectival agreement is an instance of Spec-Head agreement where the XP subject is base generated as the specifier of AP and raised to SpecIP, to get Case". This analysis is also found in, among others, Couquaux (1981), Stowell (1981:262), Burzio (1986:154), Vikner & Sprouse (1988:19), and to some extent even in Bach (1967:467).

Chomsky (1995) also belongs in this group, as he gives the following analysis of predicative adjectives (1995:(184), 354, 356):

(22) En. John is [_{AdjP} t_1 [_{Adj} t_2 intelligent]]

The subject *John* is base-generated in the position marked t_2 , i.e. in the "inner specifier" of the AdjP whose head is the Adj° *intelligent*. It then moves to the position marked t_1 , i.e. (the "outer") AdjP-spec, where adjectival agreement is "checked". Finally it moves out of the AdjP into the subject position of the clause.

I shall follow this to the extent that I assume a) that the subject of a predicative adjective construction has to be linked (presumably by movement) to an empty category inside AdjP (which represents an empty argument slot in the argument structure of the adjective), and b) that this link involves includes AdjP-spec.

Whether the empty category inside AdjP is the specifier or the complement presumably depends on the adjective in question, cf. e.g. Cinque (1990).

This also means that the copula in a predicative adjective construction does not assign any thematic role to its subject. This assumption is supported by the fact (cf. also hand-out VI later) that in the syntax of English, the copula *be* falls into the same group as auxiliary *be*, *have*, and *do* (they do not assign any thematic roles, they may occur to the left of sentential adverbs, and they do not require *do*-insertion in negated sentences) and not into the same group as all other main verbs, including main verb *have* and *do* (they assign thematic roles, they occur only to the right of sentential adverbs, and they require *do*-insertion in negated sentences).

6. Predicative adjective agreement is spec-head agreement inside AdjP

Regardless of whether the subject DP is linked to the empty specifier of AdjP or to the empty complement, I will assume the link to take the form of a chain that includes AdjP-spec. I will further follow Chomsky (1995:353-354) in assuming that the result of AdjP-spec being part of the chain is predicative adjective agreement (even though below I shall limit this to head-initial AdjPs, i.e. to AdjPs in the VO-languages). If AdjP-spec would not be part of such a chain, there would be no adjective agreement.

I thus assume that in languages with a head-initial AdjP, the subject DP of a predicative adjective construction is base-generated either in AdjP-spec, (23a) or inside the complement of Adj°, (23b,c), or. It does not matter for the purposes of this analysis whether a given DP is base-generated in one or the other of these two positions, as long as any DP that is moved out of the AdjP (by means of A-movement) has to move via AdjP-spec, i.e. as long as (23c) is ruled out.

This is trivially the case for DPs base-generated in AdjP-spec, and I will also assume that it holds for DPs base-generated inside the complement of Adj°. If the movement in question is taken to be A-movement, this would follow from e.g. Relativised Minimality (Rizzi 1990:93), which basically says that any particular type of movement may not skip any specifiers of the same type (this can be reformulated in terms of e.g. the Minimal Link Condition, Chomsky 1995:294). As both IP-spec and AdjP-spec are potential argument positions, i.e. A-positions, any movement to IP-spec which skips AdjP-spec violates Relativised Minimality, cf. the impossible (23c), in which an attempt is made to skip the specifier:

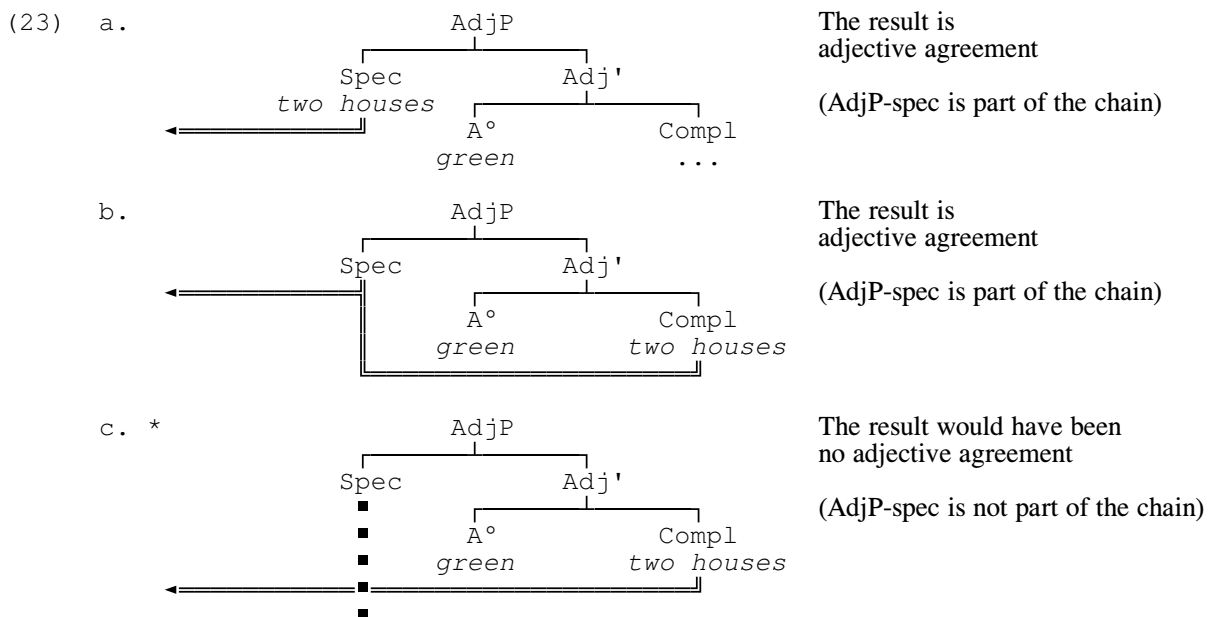

7. Spec-head agreement is a property of head-initial phrases

As you will see in hand-out VI later in the course, I will be adopting (parts of) the analysis of head-final VPs in Haider & Rosengren (1998:48-51, 2003:207-211). Their basic idea is that languages vary with respect to the licensing direction of verbs (and by extension adjectives), and that therefore VP-spec (and AdjP-spec) is exceptional in VO-languages (where it is on the "wrong" side of the verb, since the verb in VO-languages licenses to the right), whereas VP-spec/AdjP-spec is not exceptional in OV-languages (where it is on the "normal" side of the verb, since the verb in OV-languages licenses to the left).

In earlier versions of this work (Vikner 2001a,b), I also followed Haider & Rosengren's idea (e.g. 2003:208) that in OV-languages arguments of the verb may be base-generated adjoined to VP. Applying this to AdjP meant that arguments could be moved out of AdjP (into the subject position of a clause with a predicative adjective) without moving through AdjP-spec, as AdjP-spec would not intervene in the chain (it would not c-command any part of it):

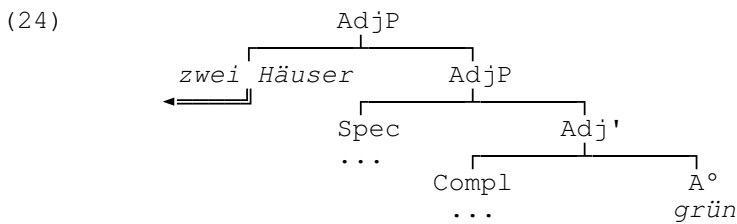

Although the result of this was that predicative adjective agreement could only be avoided in the OV-languages, it did not straightforwardly predict that it was downright impossible.

Consider now a somewhat different adaptation of the suggestions in Haider & Rosengren (1998:48-51, 2003:207-211). The idea is that spec- X° agreement is a last resort, only found in those projections where the specifier (which I take to be to the left of X' universally) cannot be licensed in the licensing direction of the head, i.e. only found in head-initial projections. This is less radical than it may sound, as I take functional projections to be head-initial universally, so that only lexical elements may vary (and only within narrow limits, see hand-out VI). In brief, there is no spec- X° agreement in VP and AdjP in German and the other OV-languages.

This means that the possibilities in the OV-languages are completely parallel to the VO ones in (23) above. Extraction has to go via AdjP-spec, regardless of whether the base-generated position is the specifier, (25a), or the complement, (25b), of AdjP. The difference between OV- and VO-languages is simply that in OV-languages, movement via AdjP-spec does not trigger overt morphological agreement.

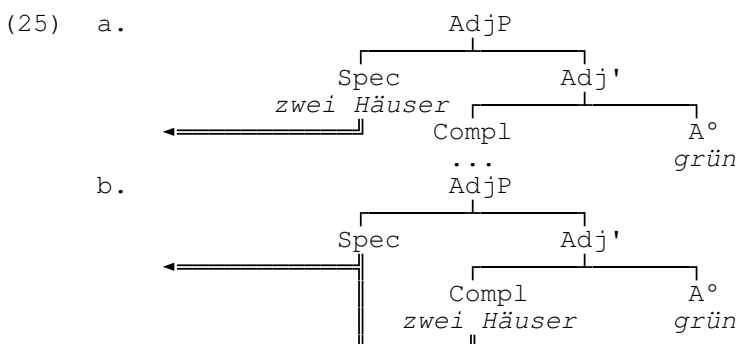

8.1 Historical predictions

Testing the two predictions for earlier stages of the Germanic languages is made difficult both by the scarcity of evidence and by the fact that the evidence that does exist is not always unambiguous. It seems that the older languages fall into three groups:

Languages with no predicative adjective agreement, e.g. **Middle Dutch** (Burridge 1993:248) and **Old Frisian** (Markey 1981:169). As these languages are always taken to be OV-languages, this is as expected.

Languages where predicative adjectives do not show any agreement in the majority of the cases, e.g. **Old English** (Brunner 1965:236, Mitchell 1985:62), **Old High German** (Paul 1917:164, Penzl 1986:55), and **Middle High German** (Paul 1998:360, Penzl 1989:82). If this is taken as evidence that predicative adjectives do not agree, then this is as expected, as these languages are commonly taken to be OV-languages. If, however, this is taken to show that some varieties/dialects of the three languages did have predicative adjective agreement, then this is unexpected.

And finally, the third group of older Germanic languages is languages where predicative adjectives do show agreement, e.g. **Old Norse** (Nygaard 1905:68) and **Gothic** (Braune 1956:74). This is not unexpected for Old Norse, if e.g. Nygaard (1905:357-358) and Hróarsdóttir (1999:318-319) are right that Old Norse was a VO-language, like the modern Scandinavian languages (contra Faarlund 1990:110, who takes Old Norse to be non-configurational). It is, however, rather unexpected for Gothic, at least if Eythórsson (1995:22), Ferraresi (1997:7, 34) and references cited there are right that Gothic was an OV-language (This last remark also goes for **Latin**: Like Gothic, it has predicative adjective agreement but it is most commonly assumed to be an OV-language).

Summing up, the data that go against the predictions made are that Old and Middle High German show predicative adjective agreement in some cases, and that Gothic always show predicative adjective agreement.

8.2 Adjective agreement in causatives

The analysis also predicts that adjective agreement in causative constructions (e.g. *make someone nervous* or *paint something green*) should co-vary with predicative adjective agreement, which it does:

- (27) Da. a. Barnets opførsel gjorde faderen nervøs_
Child-the's behaviour made father-the nervous.M/F.SG
b. Barnets opførsel gjorde forældrene nervøse_
Child-the's behaviour made parents-the nervous.PL
- (28) Ge. a. Das Benehmen des Kindes hat den Vater nervös_ gemacht
The behaviour of-the child has the father nervous made
b. Das Benehmen des Kindes hat die Eltern nervös_ gemacht
The behaviour of-the child has the parents nervous made
- (29) Da. a. De malede væggen grøn_
They painted wall-the green.M/F.SG
b. De malede væggene grønne_
They painted walls-the green.PL
- (30) Ge. a. Sie haben die Wand grün_ gestrichen
They have the wall green painted
b. Sie haben die Wände grün_ gestrichen
They have the wall green painted

The reason is that also here the argument DP (*father, parents, wall, or walls*) has a trace inside AdjP. It is even possible that the DP is actually in AdjP-spec, but this is unlikely, as a quantifier like *very* would occur between the DP and the adjective.

8.3 Participle agreement

The analysis also makes a further prediction, under the assumption that head-finality in the AdjP and head-finality in the VP cooccur. In the languages where VPs and AdjPs are head-final, we would not only expect there to be no agreement with Adj° when an argument is extracted under A-movement from AdjP (i.e. in predicative adjective constructions), we would also expect there to be no agreement with V° when an argument is extracted under A-movement from VP. The relevant constructions are those where a non-finite verb in V° shows agreement with an argument extracted to the subject position, e.g. passive and unaccusative (ergative) constructions, as the following French examples show :

- (31) Fr. a. Ce bureau_i a été [_{VP} t_i repeint_ t_i]
This desk has been repainted.M.SG
- b. Cette table_i a été [_{VP} t_i repeinte_ t_i]
This table has been repainted.F.SG
- (based on Kayne 1985:77, (31))

- (32) Fr. a. Les soldats_i sont [_{VP} t_i morts t_i] il y a des années
The soldiers are died.M.PL it there has of years
(*The soldiers have died years ago*)
- b. Les victimes_i sont [_{VP} t_i mortes t_i] il y a des années
The victims are died.F.PL it there has of years
(*The victims have died years ago*)
- (based on Kayne 1985:84, (74))

The subjects are base-generated in the object position, i.e. following the main verb, then move to VP-spec, and from there to the subject position in IP-spec. Agreement with the participles is triggered when the subjects move through VP-spec. Under the present analysis, such agreement should never occur in the OV-languages, as here there would be no spec-X° agreement inside the (head-final) AdjPs. This prediction seems to be correct, at least for the Germanic OV-languages spoken today, which never show agreement with the participles in constructions like (31) and (32), even though the same participles might show agreement used in other constructions, e.g. used attributively.

Notice that no predictions are made about subject-verb agreement, since this is agreement between the subject and not the lexical head, V°, but a functional one, I°/AgrS°/Tense°/Person°.

A potential weakness could be that the analysis has nothing to say about why predicative adjectives in the superlative lack agreement in more languages than predicative adjectives in general. Predicative superlative adjectives lack agreement not only in the languages where all adjectives lack agreement (English, Afrikaans) and in the languages where all predicative adjectives lack agreement (Dutch, Frisian, German, ...), but also in some of the languages where all other predicative adjectives show agreement, namely Danish, Norwegian and Swedish. Only in Icelandic (and conservative Faroese) is there agreement:

- (33) Da. a. Den grønne bus er størst_
The.M/F.SG green bus is biggest
 b. De grønne busser er størst_
The.PL green buses are biggest
 c. Det grønne hus er størst_
The.N.SG green house is biggest
 d. De grønne huse er størst_
The.PL green houses are biggest
- (34) Ic. a. Græni strætisvagninn er størstur
Green.M.NOM.SG bus-the.M.NOM/AKK.SG is biggest.M.NOM.SG
 b. Grænu strætisvagnanir eru størstir
Green.PL buses-the.M.NOM.PL are biggest.M.NOM.PL
 c. Græna húsið er størst_
Green.N.SG house-the.N.NOM/AKK.SG is biggest.N.NOM/AKK
 d. Grænu húsin eru størst_
Green.PL houses-the.N.NOM/AKK.PL are biggest.N.NOM/AKK
-

9. Conclusion

In this hand-out, I have tried to argue that languages with head-final AdjPs and VPs do not show predicative adjective agreement (nor any other kind of agreement with Adj° or V° under A-extraction), because in these languages such extraction may not go via AdjP-spec or VP-spec. The following predictions are made:

- (35)
1. Languages with head-final AdjPs do not have agreement on predicative adjectives.
 2. Languages with head-initial AdjPs do not have agreement only on attributive adjectives.
 3. No languages have agreement only on predicative adjectives.

These predictions seem to hold for the modern languages (with the exception noted above of the southernmost varieties of Swiss German, none of the present-day OV-languages have predicative adjective agreement), even if the predictions made for the older languages are less impressive (here the main problem case would seem to be Gothic).

The hand-out started out by noting a paradox, namely how unexpected it is that a language with so much agreement morphology as German lacks predicative adjective agreement, when predicative adjective agreement is found in languages with so little agreement morphology as Danish or French. The analysis presented resolves this paradox by setting the lack of predicative adjective agreement in the OV-languages apart from other kinds of lack (or loss) of agreement, in attributing it to a particular structural cause, head-finality in AdjP.

This allows us to keep the general view that both German and Icelandic are languages which tend to express agreement with respect to many categories (person, number, gender, case, ...) , whenever they have the chance, whereas e.g. Danish, Dutch, and English are languages which tend to either not express agreement at all or only express agreement with respect to very few categories.

References

- Abraham, Werner 1995: *Deutsche Syntax im Sprachvergleich*. Tübingen: Narr.
- Bach, Emmon 1967: "Have and be in English Syntax". In: *Language* **43.2**, 462-485.
- Braune, Wilhelm 1956: *Gotische Grammatik*. Tübingen: Niemeyer.
- Brunner, Karl 1965: *Altenglische Grammatik*. Tübingen: Niemeyer.
- Burridge, Kate 1993: *Syntactic Change in Germanic*. Amsterdam: Benjamins.
- Burzio, Luigi 1986: *Italian Syntax*. Dordrecht: Reidel.
- Chomsky, Noam 1995: *The Minimalist Program*. Cambridge: MIT Press.
- Cinque, Guglielmo: 1990a, "Two Classes of Intransitive Adjectives in Italian" in Günther Grewendorf & Wolfgang Sternefeld (eds.), *Scrambling and Barriers*, Linguistik Aktuell **5**, John Benjamins, Amsterdam, pp. 261-294.
- Corver, Norbert 1997: "The Internal Syntax of the Dutch Extended Adjectival Projection". In: *Natural Language and Linguistic Theory* **15.2**, 289-368.
- Couquaux, Daniel 1981: "French Predication and Linguistic Theory". In: Koster, Jan / May, Robert (eds.): *Levels of Syntactic Representation*. Dordrecht: Foris, 33-64.
- Delsing, Lars-Olof 1993: *The Internal Structure of Noun Phrases in the Scandinavian Languages*. Ph.D., University of Lund.
- Diesing, Molly 1997: "Yiddish VP Order and the Typology of Object Movement in Germanic". In: *Natural Language and Linguistic Theory* **15.2**, 369-427.
- Donaldson, Bruce 1993: *A Grammar of Afrikaans*. Berlin: Mouton de Gruyter.
- Eythórsson, Thórhallur 1995: *Verbal syntax in the Early Germanic Languages*, Ph.D., Cornell University.
- Faarlund, Jan Terje 1990: *Syntactic Change: Toward a Theory of Historical Syntax*. Berlin: Mouton de Gruyter.
- Ferraresi, Gisella 1997: *Word Order and Phrase Structure in Gothic*. Ph.D., University of Stuttgart
- Fuchs, Gabriela 1993: "Das prädikative Adjektive und Partizip im Walliserdeutschen". In: Helen Christen (ed.), *Variationslinguistik und Dialektologie*, Universitätsverlag Freiburg, Fribourg, pp. 65-79.
- Geilfuß, Jochen 1991: "Jiddisch als SOV-Sprache". In: *Working Papers of Sonderforschungsbereich 340* (Universities of Stuttgart and Tübingen) **11**, 3-17.
- Haider, Hubert & Inger Rosengren 1998: "Scrambling". In: *Sprache und Pragmatik* **49**, 1-104.
- Haider, Hubert & Inger Rosengren 2003: "Scrambling: Non-triggered chain formation in OV-languages". In: *Journal of Germanic Linguistics* **15.3**, 203-267.
- Hall, Beatrice 1979: "Accounting for Yiddish Word Order or What's a Nice NP Like You Doing in a Place Like This". In: Meisel, Jürgen / Pam, Martin (eds.): *Linear Order and Generative Theory*. Amsterdam: Benjamins 253-287.
- Hotzenköcherle, Rudolf 1961: "Zur Raumstruktur des Schweizerdeutschen: Statik und Dynamik". In: *Zeitschrift für Mundartforschung* **28**, 207-227.
- Hróarsdóttir, Thorbjörg 1999: *Verb Phrase Syntax in the History of Icelandic*. Ph.D., University of Tromsø.
- Katz, Dovid 1987: *Grammar of the Yiddish Language*. London: Duckworth.
- Kayne, Richard 1985: "L'accord du participe passé en français et en italien". In: *Modèles Linguistiques* **7.1**, 73-89.
- Kester, Ellen-Petra 1996: *The Nature of Adjectival Inflection*. Ph.D., University of Utrecht.
- Lockwood, William B. 1995: *Lehrbuch der modernen jiddischen Sprache*. Hamburg: Buske.
- Markey, Thomas 1981: *Frisian*. The Hague: Mouton.
- Mitchell, Bruce 1985: *Old English Syntax*, Vol. I. Oxford: Clarendon Press.

- Nygaard, Marius 1905: *Norrøn Syntax*. Kristiania: Aschehoug.
- Olsen, Susan 1988: "Das 'substantivierte' Adjektiv im Deutschen und Englischen: Attribuierung vs. syntaktische 'Substantivierung'". In: *Folia Linguistica*, **22.3-4**, 337-372.
- Paul, Hermann 1917: *Deutsche Grammatik*, Vol. II. Halle: Niemeyer.
- Paul, Hermann 1998: *Mittelhochdeutsche grammatik*. Tübingen: Niemeyer.
- Penzl, Herbert 1986: *Althochdeutsch*. Berne: Lang.
- Penzl, Herbert 1989: *Mittelhochdeutsch*. Berne: Lang.
- Ponelis, Frits 1993: *The Development of Afrikaans*. Berne: Lang.
- Rizzi, Luigi 1990: *Relativized Minimality*. Cambridge: MIT Press.
- Santorini, Beatrice 1993: "Jiddish als gemischte OV/VO-Sprache". In: Abraham, Werner / Bayer, Josef (eds.): *Dialektsyntax*. Opladen: Westdeutscher Verlag, 230-245.
- Stowell, Tim 1981: *Origins of Phrase Structure*. Ph.D., M.I.T.
- Vikner, Sten 2001a: "Predicative Adjective Agreement" in Kirsten Adamzik & Helen Christen (eds.) *Sprachkontakt, Sprachvergleich, Sprachvariation: Festschrift für Gottfried Kolde*, Niemeyer, Tübingen, 399-414.
< www.hum.au.dk/engelsk/engsv/papers/vikn01b.pdf > .
- Vikner, Sten 2001b: *Verb Movement Variation in Germanic and Optimality Theory*, Habilitationsschrift, University of Tübingen.
< www.hum.au.dk/engelsk/engsv/papers/viknhabi.pdf > .
- Vikner, Sten 2003: "Null Objects under Coordination in Yiddish and Scandinavian" in Lars-Olof Delsing, Cecilia Falk, Gunlög Josefsson & Halldór Ármann Sigurðsson, (eds.) *Grammar in Focus: Festschrift for Christer Platzack*, vol. II, Dept. of Scandinavian Languages, University of Lund, 365-375.
< www.hum.au.dk/engelsk/engsv/papers/vikn03a.pdf > .
- Vikner, Sten 2005: "Immobile Complex Verbs in Germanic", *Journal of Comparative Germanic Linguistics* **8.1-2**, 83-115.
< www.hum.au.dk/engelsk/engsv/papers/vikn05b.pdf > .
- Vikner, Sten / Sprouse, Rex A. 1988: "Have/Be Selection as an A-Chain Membership Requirement". In: *Working Papers in Scandinavian Syntax* **38**, 1-48.
< www.hum.au.dk/engelsk/engsv/papers/vikn88b.pdf > .
- Weinreich, Uriel 1971: *College Yiddish*. New York: YIVO Institute for Jewish Research.